

# Deck/Wall Mounted Fire Curtain Hoist

- Manufactured to Federal Specification RRC-271-E
- Motorized fire curtain hoist with integral speed regulation used to raise and lower fire curtains - up to 1,100 lb (499 kg)  
**Note:** Hoist is designed for constant load between 500 lb (227 kg) and 1,100 lb (499 kg);  
 brail curtains may require additional pipe weight to operate properly.
- Weight: 550 lb (249 kg)
- Max travel: Up to 30' (9144 mm)
- Available as wall mount or floor mount
- Push button control stations for easy operation
- Emergency lowering speed controlled by hydraulic speed regulator
- 50' (15.24 m) of 5/16" (8 mm) of drive line included
- Meets requirements of ANSI E1.22 – 2016 "Entertainment Technology Fire Safety Curtain Systems" or NFPA 80 "Standard for Fire Doors and Other Opening Protectives – 2016"
- Control station included
- Available for operation on 208, 380 or 480 VAC 3 phase power, please confirm voltage at time of ordering
- Three-year warranty against defects in materials or workmanship is provided on all J.R. Clancy equipment, additional warranty information is available at jrclancy.com

## Dimensions

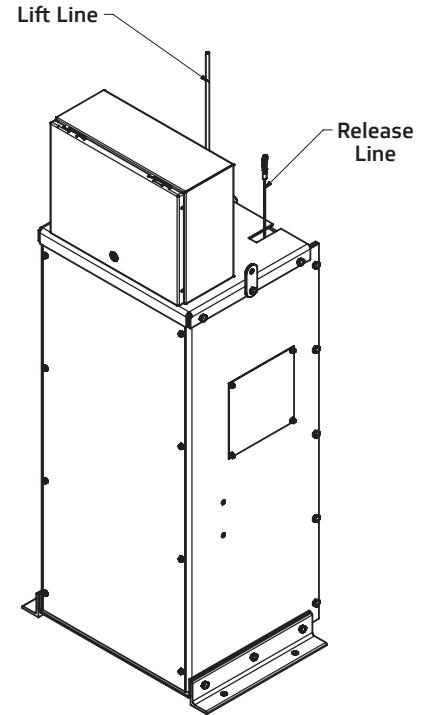
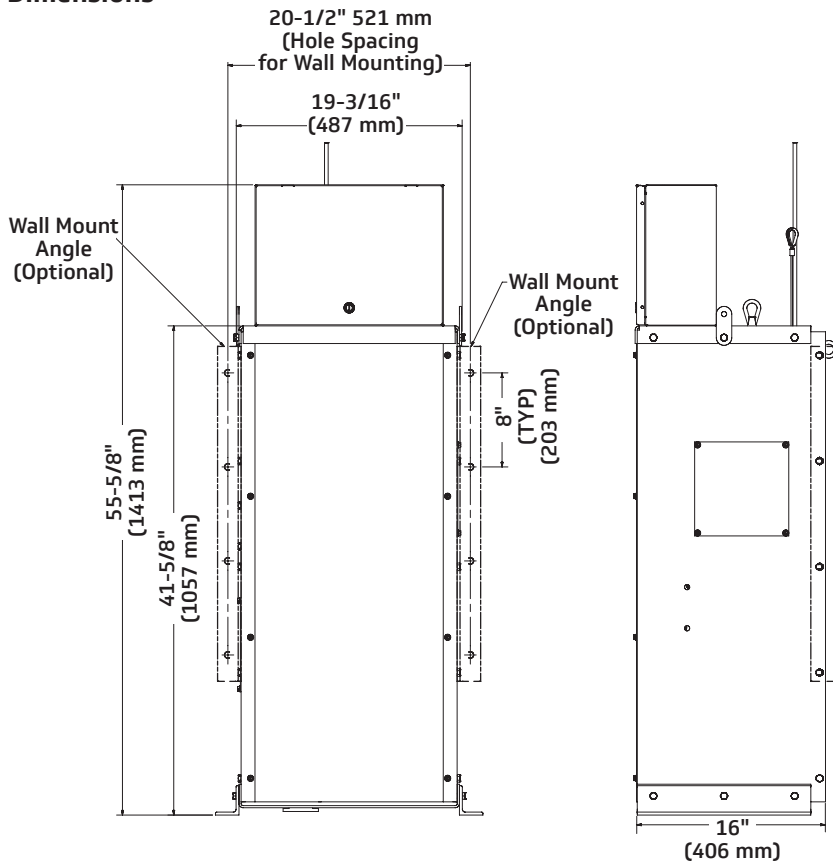

Motorized Fire Curtain Hoist

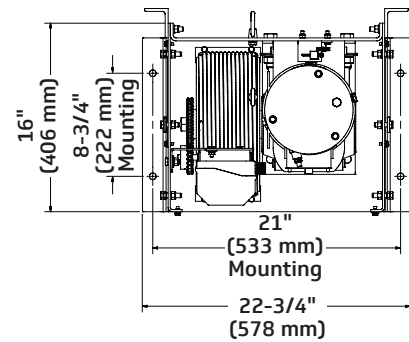

## Order Information

Model	Mounting	Voltage
016-501P-2-F	Floor	208V 60hz
016-501P-2-W	Wall	208V 60hz
016-501P-3-F	Floor	380V 50hz
016-501P-3-W	Wall	380V 50hz
016-501P-4-F	Floor	480V 60hz
016-501P-4-W	Wall	480V 60hz

